Process development for complex mine water treatment

Tim Aubel¹, Eberhard Janneck¹, Robin Kalanchoy²

¹*G.E.O.S. Ingenieurgesellschaft mbH, Schwarze Kiefern 2, 09633 Halsbrücke, Germany
t.aubel@geosfreiberg.de*

²*Eldorado Gold Corporation, 1188 Bentall 5 550 Burrard Street Vancouver,
BC V6C 2B5, Canada*

Abstract In this paper a process development for a complex mine water treatment is presented. Based on hypothetical specifications for process water /discharge quality after treatment and hypothetical assumptions for water compositions before treatment, a treatment strategy was developed. This desktop-based flowsheet was tested on a lab scale for all stages of unit processes and showed a full compliance with all discharge limits. The process development includes different options for varying water qualities, cost estimation for CAPEX and OPEX and a basic design for a full scale water treatment plant.

Key words Mine water, active treatment, reverse osmosis, nanofiltration, process water, zero liquid discharge, re-use

Preliminary considerations

The phenomenon of so-called “preg-robbing” by carbonaceous materials present in the ore is a well-known problem in the gold/silver mining industry (Miller 2005). Preg-robbing can be exacerbated by soluble chloride in process water, as it can contribute to dissolution of gold and then precipitation (reduction) of the dissolved gold during pressure oxidation and thus increase adverse effects of preg-robbing carbonaceous materials due to potential loss of gold. Chloride concentrations of as low as 50 to 100 mg/L can result in significant gold losses in some cases. For example, gold recoveries were decreased from 95% to about 90% at 15 mg/L chloride concentration in the process water.

The presence of organic carbon (carbonaceous material) in the ore and chloride in the process water can render processing strategies economically unattractive and this prevent the development of selected mine projects. How to mitigate the effects of chloride in the process water presents a unique challenge of treating the process water to meet multiple objectives:

- operate the ore processing plant with a minimum amount of fresh water make-up;
- recycle the reclaimed water from a tailing management facility (TMF) for ore processing;
- remove chloride from the reclaimed TMF water to a targeted concentration of less than 10 mg/L and
- meet all government discharge limits on occasions when discharge of treated water to the environment is required (Beyond metals the sulphate may be subject to discharge limits between 250 and 2000 mg/L depending on national regulations and site specific conditions (for example: Peru, Brazil: 250 mg/L , Chile: 1,000 mg/L)).

When discharge to the environment is required the process water will be treated to meet

the government discharge limits, which are particularly stringent for calcium, sulphate and heavy metals. For the purpose of recycling in the process plant, the process water will be treated to achieve chloride concentration below 10 mg/L.

For the current study, two different water qualities were selected as examples for a hypothetical acid mine drainage (AMD) and for a hypothetical reclaimed water from a TMF of a gold mine/processing plant, respectively. The relevant compositions of these two water qualities are listed in Table 1.

Table 1 Water Composition

	Acid Mine Drainage	Reclaimed TMF water
Sulphate (SO ₄)	8,800 mg/L	4,800 mg/L
Iron	2,000 mg/L	<0.043 mg/L
Aluminium	330 mg/L	0.24 mg/L
Manganese	260 mg/L	2 mg/L
Chloride	1.8 mg/L	240 mg/L
Potassium	4.6 mg/L	780 mg/L
Sodium	8.5 mg/L	1,100 mg/L
pH	2.7	9.0

Based on these water compositions, two different flowsheets were selected comprising reliable and efficient water treatment technologies. Both flowsheets met the project objectives with special view to the variable influent water streams.

Treatment strategy for Contact water (such as acid mine drainage)

- pretreatment using limestone and lime
- ettringite precipitation or nanofiltration for sulphate removal
- pH adjustment with CO₂

The idea of nanofiltration for sulphate removal was discarded after preliminary lab tests of nanofiltration with contact water because scaling problems inside the nanofiltration modules could not be solved.

Treatment strategy for reclaimed water from TMF

- nanofiltration for sulphate removal
- reverse osmosis 1
- reverse osmosis 2 for the concentrate from reverse osmosis 1
- evaporation for the concentrate from reverse osmosis 2
- immobilization

Results

Contact water (acid mine drainage)

For the treatment of a hypothetical contact water composition, different types of limestone and lime were tested for pH adjustment.

For the pH adjustment with limestone and lime, the following test parameters showed the best results and were suggested for the basic design:

- dosage of limestone: 6 kg/m³ contact water
- quality: fine ground limestone, 95% passing 90 µm, 90% CaCO₃
- reaction time: 15 min
- air sparging during limestone addition
- pH around 2.7 in the beginning, pH 4.3 in the end

followed by

- dosage of hydrated lime: 5.65 kg/m³
- lime milk 10-20 wt-% of Ca(OH)₂
- reaction time: 30 min with continuous stirring
- pH adjustment: 10.5
- flocculant type: A130 (anionic)
- flocculant dosage: 1 g/m³
- sedimentation time of the sludge : 2 h

After pH adjustment using limestone and lime, TDS, sulphate, calcium and aluminium did not meet the government discharge limits. Therefore, additional treatment steps including ettringite precipitation and pH adjustment with CO₂ were necessary.

The following test parameters for the ettringite precipitation were elaborated and suggested for the basic design:

- set-point pH during ettringite precipitation: ≥ 11.5
- lime consumption to maintain pH ≥ 11.5: 1.35 kg/m³
- specific dosage for sulphate removal: 1.8 g ISTRA50 cement per g SO₄ to remove
- reaction time: 2 hours with continuous stirring
- flocculant type: C248 (cationic)
- flocculant dosage: 20 g/m³
- sedimentation time of the sludge : 2 h

followed by the final pH-adjustment with CO₂:

- set-point pH: 7.5 – 8.0
-

- CO₂ consumption for pH adjustment: 0.5 kg/m³
- reaction time: 30 min
- flocculant type: A130 (anionic)
- flocculant dosage: 0.5 g/m³
- sedimentation time of the sludge : 1 h

Application of the above additional treatment steps finally enabled compliance with all government discharge limits. Chloride removal was not necessary because chloride concentration of the untreated water was already below 10 mg/L.

TMF Water

The treatment of the reclaimed water from the tailing management facility was a more complex issue. High sulphate concentration combined with an ambitious treatment goal for chloride and a demand for a maximum yield of ready-to-use clean process water led to the decision to apply a three-stage membrane process followed by evaporation and immobilization for very highly concentrated salt solutions. The ettringite precipitation for sulphate removal was identified as being unsuitable because of very high lime consumption, a high content of TDS after treatment, very long reaction times and insufficient sulphate removal due to high concentrations of Na⁺ and K⁺ as cations, which keep anions (such as sulphate) in the water to maintain electro neutrality.

All membrane tests were carried out with a cross flow membrane device with an area of 200 cm² flat sheet module.

Separation of sulphate and chloride was necessary at the first stage. Therefore, nanofiltration (NF) membrane with a good retention of sulphate and high permeability for chloride had to be identified in a first membrane screening.

Different nanofiltration membranes were tested. The results are listed in Table 2.

Table 2 Sulphate/chloride separation with nanofiltration

Membrane type	Sulphate rejection	Chloride rejection
DOW NF 90	99.9 %	94.5 %
NADIR NP030	77.5 %	- 13.6 %
General Electric – CK (GE-CK)	96.0 %	- 4.0 %
General Electric – DL (GE-DL)	99.5 %	- 20.6 %

The negative retention of chloride can be explained by the “Donnan-Effect” (Krieg 2004, Levenstein 1996). The monovalent cations Na⁺ and K⁺ can partly pass the nanofiltration membrane but their bivalent counterion sulphate is rejected. Therefore the monovalent chloride has to preferably pass the NF membrane to ensure electroneutrality of the solution.

The effect did not appear with NF90 membrane because the NF90 is a very dense NF membrane, which is passed only by a very small percentage of monovalent cations Na^+ and K^+ . A chloride transfer to the NF permeate is helpful for the process design in general, for the chloride transfer out of the system and for chloride separation from sulphate.

Therefore, the GE-DL membrane was selected for all following investigations with nanofiltration.

After several pre-tests of reverse osmosis (RO) membranes, a full stage test run with NF stage, two RO stages, evaporation and immobilization was conducted with full analysis of all solution flows.

The three-stage membrane tests were run with 80% permeate recovery, operating pressure of 10 bar for NF membrane and 25 bar for RO membrane and room temperature. The antiscalant Flocon 135 was used according to the supplier's recommendations. The chosen membrane types were

- GE-DL membrane for NF
- GE-AG membrane for both RO stages.

This selection was based on several pre-tests by choosing the membranes with best stability, flux and separation results.

Selected results are given in Table 3.

Table 3 Selected results of membrane stages

		TMF Water	Nanofiltration		Reverse Osmosis 1		Reverse Osmosis 2	
			Perme- ate	Concen- trate	Perme- ate	Concen- trate	Perme- ate	Concen- trate
Flow	L/m ² h		20.5		83.6		55.8	
Conduc- tivity	mS/cm	9.25	1,470	28,200	235	6,200	150	25,400
TDS	mg/L	8,800	820	31,000	360	3,800	81	19,000
pH		7.97	7.93	7.68	6.65	8.23	6.71	8.35
Sulphate	mg/L	4,800	290	20,000	24	1,300	11	5,200
Magne- sium	mg/L	120	5.1	610	0.5	23	< 0.5	110
Chloride	mg/L	240	300	9.7	5.2	130	27	5,100
Calcium	mg/L	530	17	510	< 0.5	88	0.51	420
Sodium	mg/L	1,100	190	4500	3.3	890	14	4,000
Potassium	mg/L	780	130	3,300	1,4	570	8.4	2,500

The blended permeates of the two RO stages met all discharge limits and all requirements for make-up water in the ore processing (chloride < 10 mg/L).

The RO2 concentrate can be evaporated and the evaporation condensate can be used for make-up water as well.

During the whole TMF water treatment process, two waste streams were generated: 1) the NF stage concentrate, which can be sent back to the TMF after desaturation for gypsum removal, and 2) the RO2 (stage) concentrate.

For the second waste stream, a separate treatment is necessary to avoid chloride build-up. Two different strategies are possible to achieve this aim:

- evaporation until crystallization and separate disposal (not tested in this study)
- immobilization with cement

The immobilization with cement was done with artificial salt solution, due to limited amount of available RO2 concentrate. Two salt solutions were defined:

- solution 1: 2,600 mg/L sulphate added as Na₂SO₄
9,600 mg/L chloride added as NaCl
- solution 2: 13,000 mg/L sulphate added as Na₂SO₄
48,000 mg/L chloride added as NaCl

Solution 2 should represent an 80% volume reduction of the RO2 stage by evaporation before immobilization.

The two different solutions were mixed with two different cement types:

- Calcium Aluminate Cement (Istra50)
- Portland cement CEM II/B-M (S-LL).

Each mixture was prepared in two different solid/liquid ratios of 1:1 and 2:1. The slurry was molded in styrofoam boxes and was left for curing which took 1, 7 and 28 days for each slurry mixture. After the different curing times, compressive strength tests, S4 leaching and monolithic leaching tests were carried out.

For the compressive strength test, all results were in the magnitude of C8/C10 concrete. If necessary these immobilized blocks can be used for construction purposes at a mine site.

The elution results showed some exceedances for theoretical elution limits regarding chloride, especially in case of solution 2 and a solid/liquid ratio of 1:1. Sulphate values were always below all theoretical elution limits. Further studies will have to optimize the aspect of chloride solidification but should be customized for the specific mine site.

Basic Design/Cost calculations

The laboratory test results were a very strong basis for the basic design and cost calculations of a full scale treatment plant.

It was assumed that in 85% of the mine's life time water from the TMF has to be treated and 15% of the total water volume to be treated is not from the TMF. Different scenarios with varying water qualities, especially for AMD water quality, were considered.

CAPEX for all different scenarios were very similar and ranged between 12.7 and 14.6 million € assuming a treatment plant capacity of 350 m³/h.

OPEX varied in the worst case scenario between 1.24 and 3.07 €/m³ water and in an average scenario between 1.21 and 2.26 €/m³ water. Immobilization with cement represents the biggest cost share (> 50% of OPEX). Further investigations on evaporation/crystallization of chlorid salt solutions to a solid salt and external or underground storage without cement dosing are still necessary and would lead to important cost savings.

Summary

In this study for mine water treatment, two different hypothetical mine water compositions (acid mine drainage, reclaimed water from a TMF) were tested for the best treatment strategy. A precipitation process using limestone/lime was chosen for the AMD water and a three-stage membrane process for the reclaimed water from the TMF. Thereby the requirements for a nearly chloride free process water were taken into account. The desktop-based treatment strategies were tested in the laboratory.

Both treatment options were shown to produce water which is compliant with government discharge limits. In the case of the TMF water treatment, the developed flowsheet was shown to be technically feasible for chloride removal as required for the process facility.

Based on the results from the laboratory testing, a basic design as well as CAPEX and OPEX for a full scale treatment plant were determined.

Acknowledgements

The authors thank Eldorado Gold Corporation for financing and supporting this process development, the valuable information about gold extraction processes and the inputs during lab tests.

References

- Krieg HM, Modise SJ, Keizer K, Neomagus HWJP (2004): Salt rejection in nanofiltration for single and binary salt mixtures in view of sulphate removal, *Desalination*, Vol. 171, p. 205 – 215
- Levenstein R, Hasson D, Semiat R (1996): Utilization of the Donnan effect for improving electrolyte separation with nanofiltration membranes, *Journal of Membrane Sciences*, Vol. 116, p. 77 – 92
- Miller JD, Wan RY, Diaz X (2005): Preg-robbing gold ores, *Advances in Gold ore processes*, Vol. 15, Chapter 38, p. 937 – 972

Electromembrane Processes in Mine Water Treatment

Jan Kinčl¹, Tomáš Jiříček¹, Jakub Fehér¹, Michal Amrich¹, David Neděla¹,
František Toman², Bohumil Velen², Jiří Cakl³, Jan Kroupa³

¹*MemBrain s.r.o., Pod Vinicí 87, Stráž pod Ralskem, Czech Republic;*

²*DIAMO s.p. o.z. GEAM, Dolní Rožínka 86, Czech Republic;*

³*University Pardubice, Studentská 95, Pardubice, Czech Republic*

Abstract Electro dialysis and bipolar electro dialysis were used in two case studies with uranium mine waste water:

1. Electro dialysis increases Na₂SO₄ concentration before evaporator

2. Bipolar electro dialysis produces 1.5 % H₂SO₄ and 4 % NaOH for local reuse

New pilot and industrial units were designed and constructed with 1 m² and 33.3 m² of membrane surface, respectively. While the pilot module was operated for 11 months since March 2016, the industrial module has been in operation since March 2017. With the electricity consumption was 2.0 kW per kg of recycled Na₂SO₄, the operating cost now approximates the value of recycled chemicals.

Key words bipolar electro dialysis, uranium mine water, sodium sulphate

Introduction

ED has proved to be a good and economical choice for the treatment of waste waters polluted by inorganic salts. It has been successfully applied for recirculation of valuable products from waste waters containing quite pure salts, such as electroplating baths or fertilizers, as well as for recycling of industrial water, e.g. pulping process, acid pickling, or cooling tower blowdown (Koltuniewicz 2008). EDBM uses a unique type of ion exchange membrane by which acids and hydroxides can be produced from their respective salts (Strathmann 2004).

Application in mining industry, such as tailing pond overbalance, landfill leachate, or mine water treatment present further opportunities for the application of electromembrane processes. Large amounts of water containing high salt concentration are often treated by evaporator (EV) and crystallization, and the produced crystalline solids are marketed. Application of ED for salt concentration is a feasible way of decreasing the large operation costs for EV, given its significant power consumption. Moreover, EDBM presents an option how to recycle and reuse the original chemicals, leading not only to decreasing the cost of their purchase, but also lowering the final waste water volume.

Theory

In a direct current electric field bipolar membranes (BPM) allow for splitting of water molecules. In order to form an acid or a base, also monopolar anion exchange (AEM) and cation exchange (CEM) membranes are employed, carrying out a separation of cations and anions from the feed solution in a traditional ED process.

A cell system (fig 1) consists of AEM, BPM and CEM membranes as a repeating unit. The feed solution flows between the CEM and AEM. Water will dissociate in BPM to form equivalent amounts of H⁺ and OH⁻ ions. The H⁺ ions permeate through the cation-exchange side

of the BPM and form H_2SO_4 with the sulphate ions provided by the sodium sulphate solution from the adjacent cell. The OH^- ions permeate the anion-exchange side of the BPM and form NaOH with the sodium ions permeating into the cell from the salt solution through adjacent CEM. The final result is the production of NaOH and H_2SO_4 at a significantly lower cost than by other methods

This three-circuit arrangement was found to be the most suitable for this particular application (Kroupa 2015). Other arrangements were tested as well, but none proved to be significantly better in overall performance to warrant its use. In these tests, the maximum achievable concentration was about 5 % wt. for both products. Above these concentrations, product purity and electric current efficiency would drop significantly, due to excessive water dissociation and transport of undesired ions.

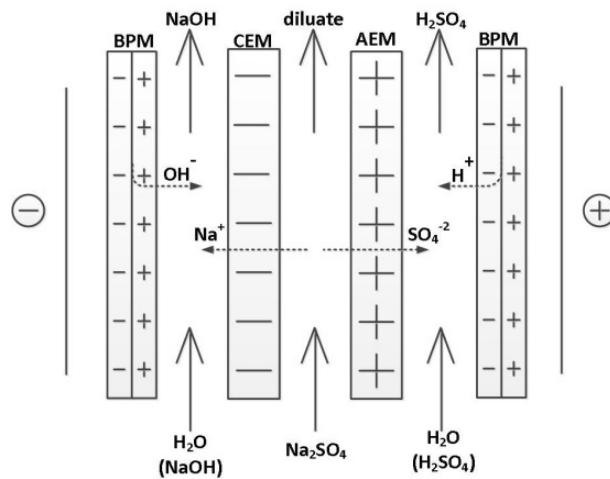

Figure 1 Principle of EDBM in a three circuit arrangement (Kroll 1997).

Case study 1 – Tailing pond of uranium mill, 65 m³/h, Czech Republic, 2007

Water coming from a tailing pond of uranium production is cleaned by a combined membrane technology based on ED and RO with proper pre-treatment. The final technology was designed based on 6200 hours of pilot testing.

Pilot testing

To obtain reliable data for scale up, a complete pilot technology was installed on site, including chemical pre-treatment, ED and RO (Černín 2007). Three sources were fed into the technology: sludge bed water, drainage water and their 2:1 mixture. Process data were logged three times a day, including the analysis of sulphates and total organic carbon.

Pre-treatment process had to be enchased as AEMs were losing their long term electric properties. Sulphonated polystyrene structures were found to be the major pollutant, caus-

ing membrane fouling and consequent membrane poisoning. Concentration of these compounds was decreased by oxidation and adsorption on active carbon.

Industrial technology

Industrial technology (fig 2) consist of precipitation of calcium and magnesium by lime and soda ash, sedimentation, sand filtration, sorption of heavy metals and uranium in ion exchange columns, oxidation, sorption of oxidation products on active carbon and acidification by sulphuric acid. 65 m³/h of pretreated water with total dissolved solids (TDS) 35 g/L is partially desalted by ED to 12 g/L. ED diluate is further desalted by RO reaching TDS of 0.18 g/L and discharged into the local river, while meeting the effluent restrictions. RO retentate is mixed with the ED feed. The final step of current technology is the concentration of ED concentrate having TDS of about 110 g/L by EV, preceding the sodium sulphate crystallization.



Figure 2 ED (left) and RO (right) in the GEAM plant (Toman 2009).

Technological parameters of the installed technology were compared with the previous technology based on EV only (tab 1). Electric energy consumption is about the same for the combined process as for EV alone due to large consumption of EV caused by circulation pumps. Large heat consumption of EV is reduced by 37% because of increase of EV feed concentration by upstream ED + RO. Water recovery was slightly increased too. The only drawback of membrane processes is their chemical consumption, but comparison to the huge saving on heat, the costs of common chemicals are almost negligible.

Table 1 Technological comparison of EV and the combined process (Toman 2009).

Parameter	EV	ED + RO + EV
El. energy consumption (kWh/m ³)	26.02	25.22
Heat consumption (GJ/m ³)	0.62	0.39
Clean water recovery (%)	77	80
H ₂ SO ₄ consumption (kg/m ³)	0.663	2.51
NaOH consumption (kg/m ³)	0	0.2

The latest technology, based on modern ED modules EDR-II/200-0.8 (MEGA a.s., Czech republic), has been in operation since 2007 without any difficulties. ED and RO membranes are cleaned chemically three times per year. Less than 1% of ED membranes were replaced so far. The first RO membranes lasted in the technology for 6 years. The customer now treats up to 440,000.0 m³/year of waste water.

Case study 2 – Application of EDBM for recycling of sulphuric acid and sodium hydroxide, Czech Republic, 2016 -- now

As the market demand for crystalline sodium sulphate is low, new technologies are being investigated. EDBM was chosen as both products can be reused on site. About 7 % of total sodium sulphate contained in the waste water is processed (fig 3).

Development of EDBM components

Bipolar membranes

Easier production is the major developmental step in the third version of heterogeneous membrane Ralex® BM-3.0. Previous heterogeneous BPM Ralex® was hot-pressed to form necessary internal microstructure (Neděla 2015). Ralex® BM-3.0 is produced by simple co-extrusion of two layers and its capacity, energy consumption, selectivity, chemical and mechanical stability remains the same as for hot-pressed BPM.

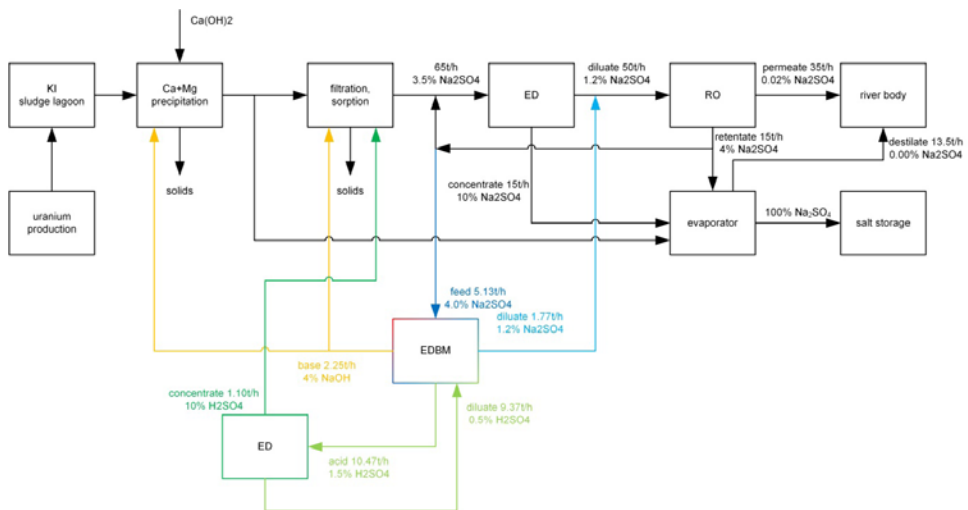

Figure 3 Current (black) and future (colour) technology in the uranium mine waste water treatment facility.

EDBM modules

Three sizes of EDBM modules were developed (fig 4):

- *Laboratory module* EDBM-Z with active membrane surface of 0.032 m², best suited for laboratory testing of new BPM samples and preliminary estimate of process parameters.

- *Pilot module* EDBM-Y with active membrane surface of 1 m², allowing for optimization according to product quality and costs.
- *Industrial scale module* EDBM-II with active membrane surface of 33.3 m².

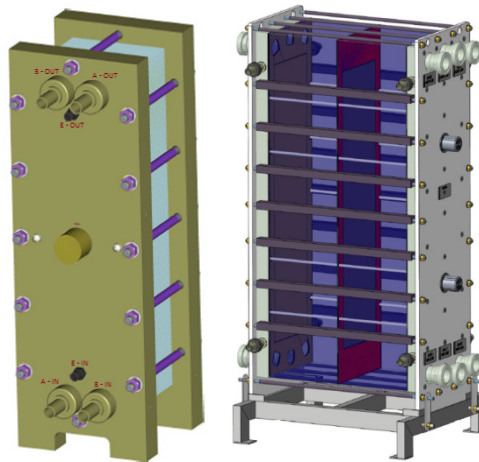

Figure 4 Pilot module (left) and industrial scale module (right).

To evaluate the module and membrane performance, a set of standardized laboratory and pilot test based on sodium sulphates were established. All modules fit their limits of external leakage (lower than 0.3 L/m²/h), internal leakage (lower than 0.024 L/m²/h), capacity (salt transport intensity higher than 0.4 kg/m²/h), energy consumption (current efficiency higher than 60 %, energy consumption lower than 2 kW.h/kg of transported salts) and product purity (higher than 85 % for both acid and base).

EDBM units

Two new units to run EDBM modules were developed:

- *Pilot unit* P1 EDBM-Y was developed for long term pilot testing, operating EDBM-Y module in batch, feed-and-bleed or one-pass mode. Automatic logging of process parameters is included, allowing for the evaluation of optimum flowrate, voltage and product concentration, and their effect on capacity, energy consumption or current efficiency.
- *Industrial unit* B15 EDBM-II based on an existing ED unit was developed for long term industrial scale testing.

Laboratory scale tests

A three-circuit EDBM module proved to be the most effective as addition of protective compartments had no positive effect on process performance, and reduction to two compartments was not suitable due to lower product concentration and purity. Optimum voltage was found to be 3 V/cell in order to achieve industrially acceptable salt transport intensity of about 0.4 kg/m²/h.

The largest possible flowrate is favourable for EDBM operation, given that (i) the pump energy consumption is by an order of magnitude lower than that of ion transport, and (ii) the boundary layer, where slow diffusion prevails, is less developed at increased flowrates. Flowrate is only limited by the pressure drop of industrial EDBM module and should be kept below 0.5 bar, typically occurring at linear velocities of around 0.07 m/s.

4.0 % wt. hydroxide and 1.5 % wt. acid were found to be optimum product concentrations, while providing acceptable purity and current efficiency. The base can be reused at site directly; the acid requires further concentration on existing ED technology to reach to 10 % wt.

Pilot tests

During 11 months of pilot testing the unit has been in stable operation, producing the required product concentrations and approaching purities of 80 %. Compared to the laboratory tests, the pilot unit was operated at lower current densities of about 350 A/m² with current efficiency of about 62 %. Energy consumption of 2.0 kWh/kg of transported sodium sulphate could not be compared to previous studies as the operating conditions differed considerably.

Industrial scale tests

Industrial production started in March 2017 on the newly developed B15 unit with one EDBM-II module. As the data cover less than one month of operation it is still early to publish any results. However, before the end of 2017 a feasibility study based on industrial scale data will be completed.

Operation costs

In the projected application of EDBM into existing technology (fig 3), the feed is 5.13 t/h of RO retentate with 4.0 % sodium sulphate. EDBM products are 1.77 t/h diluate with 1.2 % sodium sulphate, which is used as RO feed, 2.25 t/h of 4.0 % NaOH, which is used directly on site, and 10.47 t/h of 1.5 % H₂SO₄, which is concentrated in existing ED to 1.10 t/h of 10 % H₂SO₄, while 9.37 t/h ED diluate with 0.5 % H₂SO₄ is recycled back to EDBM for acid solution make-up. Exiting ED capacity should remain approximately constant. Time needed for H₂SO₄ concentration should be freed by decreasing salt amount for desalination by feeding a part of 4 % sodium sulphate solution into EDBM.

The estimate of operation costs (tab 2) is based on 11 month of pilot testing, given the electric energy price (0.064 €/kWh) and 300 workdays in a year. Electrical energy is 88 % of total operation costs, remaining 12 % are spare parts, such as membranes, spacers, and electrodes.

Current price of produced acids and bases is 317,034 €/year at given chemical prices (210 €/t 50 % NaOH and 55 €/t 94 % H₂SO₄). That is much more than operation costs of 223,358 €/year, operating profit is 119,410 €/year only by reduced chemicals purchase. EDBM technology brings more flexibility to the water treatment on site. Large EV with large operation expenses does not have to run permanently and crystalline sodium sulphate is not produced when capacity demand is low such as during a low rainfall winter period.

Table 2 Operation costs of EDBM.

	Operation cost (€/year)	Operation cost (%)
Electric energy	195,970	88
Chemicals	62	0
Spare parts	27,326	12
Total operation costs	223,358	100

Conclusions

Combination of desalination and concentration technologies proved to be the most competitive when compared to using each technology separately. Combined technology of ED, RO and thermal concentration (EV, crystallizer) decreases both investment and operation costs of waste water treatment and brings us closer to zero liquid discharge. In this combination:

- Thermal step is used for production of solid salts and reduction of salt discharge into water bodies.
- ED is used for decreasing both investment and operating costs of the thermal step. Concentration of the EV feed up to 18 % wt. brings significant heat consumption savings. Total costs are lower with membrane processes despite the need of larger chemical and mechanical pre-treatment.
- RO is used for meeting strict water discharge limits while RO retentate is pumped back into ED without any additional costs.
- Long membrane lifetime of both RO and ED is achievable with proper pre-treatment.

New heterogeneous BM-3.0 used in new laboratory and pilot scale modules was used for production of sulphuric acid and sodium hydroxide from sodium sulphate, with salt transport intensity 0.45 kg/m²/h, 62 % current efficiency and energy consumption 2.0 kWh per kg of transported salt. Application of EDBM technology on DIAMO s.p., division GEAM is economically feasible because of the eliminated costs for the recycled chemicals. EDBM brings also higher flexibility for changing capacity needs in case an unusual weather change occurs.

Acknowledgements

This work has been supported by the Technology Agency of the Czech Republic under the project no. TH10131077 „Production of NaOH and H₂SO₄ from waste Na₂SO₄ by electro dialysis with bipolar membrane“ within the framework of Project no. LO1418 “Progressive Development of Membrane Innovation Centre” supported by the program NPU I of Ministry of Education, Youth and Sports of the Czech Republic, using the infrastructure Membrane Innovation Centre.

References

- Černín A, Kysela V, Mejta V (2007) Zpracování multikomponentních odpadních vod elektrodialýzou v uranovém průmyslu, Book of abstracts CHISA Conference, Prague
- Koltuniewicz AB, Drioli E (2008) Membranes in Clean Technologies, Wiley – VCH Verlag GmbH & Co. KGaA

- Kroll JJ (1997) Monopolar and bipolar ion exchange membranes mass transport limitations. Enschede: Dept. of Chem. Eng., University of Twente.
- Kroupa J, Cakl J, Kínčl J, (2015) Increasing the concentration of products from electro dialysis with heterogeneous bipolar membrane, Innovative remediation technologies – research and experience, 8.
- Neděla D, Křivčík J, Válek R, Stránská E (2015) Influence of water content on properties of a heterogeneous bipolar membrane, Desal. Wat. Treat. 56, 3269–3272
- Strathmann H (2004) Ion-exchange membrane separation processes, Boston: Elsevier.
- Toman F (2009) Membrane processes in a water treatment at the uranium chemical mill, Book of abstracts PERMEA, Prague