

*International Journal of Mine Water*, Vol. 4, No. 1, (1985), p.33-42

Printed in Granada, Spain

#### ADVANCED GROUTING OF 960-m-LEVEL

#### SHAFT STATION IN NAGOLCHANSKAYA MINE

Ju. A. Polozov\*, Ju. N. Spichak\*\*, and V. A. Lagunov\*\*\*

\* C.Sc.Min.Eng., Vice Director General

\*\* C.Sc.Min.Eng., Chief Engineer

\*\*\* C.Sc.Min.Eng., Principal

Specialized Association Spetstamonazhgeologia,  
7a Petrovski St., Anratsit,  
Voroshilovgrad Region, USSR.

#### ABSTRACT

The paper deals with the results of development and use of a new, reliable method for sealing water bearing rocks during shaft station drivage which allows pregROUTING within the entire area of a future shaft station to be executed prior to the commencement of driving operations. The new method involves the preparation and injection of a cheap and efficient clay-cement grout into water bearing strata employing the use of high-production equipment located on the surface.

#### INTRODUCTION

Shaft station drivage under severe hydrogeological conditions, is according to current mine construction practice, mostly carried out using cementation from the face of openings in the course of their drivage. Employing that organization of work, it is necessary to stop the drivage, to erect a concrete plug in the face of an opening or to leave thick protective pillars. In addition, a large number of holes must be drilled, to prepare and inject cement grout underground. All this drastically cut down the advance rates and increases construction time both of a shaft station and of the entire mine.

On intersecting large water bearing fissures with an excavation, cementation proves to be either practically impossible, or at best requires considerable wastage of the cement grout because of its washing out from fissures by flowing strata water prior to the beginning of grout setting.

Thus, the main shaft and 960-m-level shaft station of the Nagolchanskaya 1-2 Mine had originally been planned to be excavated using from-the-bottom cementation technique. In an earlier application of this technique at a shaft depth of 922.0 m pre-cementation had been carried out in the 930.7 - 974.5 m interval of a fissured sandstone aquifer with an expenditure of 1,120 tonnes of cement. In the course of drilling a

subsequent test hole an ungrouted watered fracture 0.4 m wide was encountered resulting in an inrush of water into the shaft with an inflow of 260 m<sup>3</sup>/hr and hydrostatic pressure of 2.5 MPa flooding the shaft [1]. Undoubtedly, if the from-the-bottom cementation technique had been used during 960-m-level shaft station drivage, the effect would have been just the same.

#### BASIC FEATURES OF METHOD

To ensure the reliable sealing of water bearing strata within which a shaft station or a series of drivages is being designed, a new method of advanced grouting within the entire area of a shaft station and prior to the commencement of drivage has been developed at the Spetstamponazhgeologia association.

Major engineering decisions of the new method are as follows :

- o At the intersection point of the shaft with the shaft station level a drilling bay is excavated for the drilling equipment.
- o A fan-pattern series of long holes is drilled from this bay the pattern being related to the bedding parameters of fissured zones and geometry of fissure systems. These holes intersect the entire water bearing strata at a level of the future shaft station.
- o The conformity between the actual and designed course of a hole is controlled during drilling by an inclinometer.
- o On the intersection of the foregoing water bearing zone by each hole, a hydrodynamic investigation programme is carried out employing a special flowmetering technique.
- o From the data of the flowmetering investigations, the major hydrodynamic parameters of the water bearing zone are determined, the grout volume for creating the designed sealing barrier is calculated, and injection patterns are set up.
- o The grout is injected into each water bearing zone separately using the DAU-1 packers to plug up the hole.
- o Grouts are prepared at the surface plant. They are injected by means of high-production grouting equipment on the surface through a high-pressure line laid down the shaft and protected by a steel-tube casing.
- o Reliability of sealing each water bearing zone is controlled by means of pressurizing the hole by water up to a pre-determined value.

#### INTRODUCTION OF METHOD

Pregrouting of water bearing rocks within the entire area of a shaft station and prior to the commencement of drivage has, for the first time, been carried out in the Nagolchanskaya 1-2 Mine, Donbass, during the 960-m-level shaft station excavation designed in the 43-m-thick water

bearing sandstone [2]. The predicted water inflow into its workings amounted to 1,430 m<sup>3</sup>/hr. The strata water pressure exceeded 2.5 MPa.

Studies of the development of fissuring indicated that the sandstone aquifer had two systems of fissuring within the mine field of the Nagolchanskaya 1-2 Mine. The main system has a dip angle of 82-86° and azimuth of 5-10°, and is represented by separate fissures of several millimetres up to 1 m, and more, in width. The subordinate system has the same dip angle and an azimuth close to the normal in regard to the main system; the opening of fissures equals up to 0.2-1 mm. In the sandstone in which the shaft station was designed, the second system is not traced out, i.e. the fissures are practically isolated from each other.

To reduce construction period of the shaft station, it was proposed to shut off water inflows prior to the commencement of drivage, making grouting operations coincident with the shaft sinking and construction of a discharge bunker for coal and waste rock.

Accordingly a fan-pattern series of holes was drilled from the 960-m-level bays. The angles between the holes were in the range of 8 to 39° so that the angle of intersection between the holes and fissured zones was not less than 15° (Fig.1). The drilling sequence was chosen so that the holes No.8 and No.16 enable a survey to be made to trace the location of all fissured zones. Holes No.3 and No.13 were drilled over the sandstone zone to investigate water characteristics of that area.

Thus to execute pregrouting within the 960-m-level shaft station, 17 horizontally directed holes with a diameter of 76 mm and from 47 to 170 m long were drilled (see Fig.1). The total length of drilling amounted to 1,770 m. Taking into account that during drilling the excavation could have been inundated with pressure water, each hole was drilled in three stages with the aim of ensuring safety of operation, as described below.

Firstly, a 59-m-diameter surveying hole was drilled up to the stand-pipe depth. Secondly, the hole was redrilled to accommodate a stand-pipe with a diameter of 112 mm. The combination of the standpipe and a special capper (Fig.2) made it possible to carry out operations under hydrostatic pressure head of strata water exceeding 2.5 MPa. Finally, the grout hole was drilled with a diameter of 76 mm. On intersecting an aquiferous fissured zone by the hole, drilling was stopped, and the tool was run out of the hole through a locking chamber (Fig.3). Following this, a hydrodynamic investigation programme was carried out with the DAU-3M-G flowmeter designed specially for horizontal underground boreholes (Fig.4). From the data of hydrodynamic investigations corrections to the initial design patterns in respect of the volumes of grout injection were introduced, allowing for measured hydrostatic pressure in the aquifer, opening and length of fissures, strata thickness, and borehole spacing.

The course of a borehole was continuously controlled in the process of drilling by means of inclinometric surveys.

On intersecting each aquiferous fissured zone, the hole was plugged up with the DAU-1 packer, the injection pipeline was connected to it and

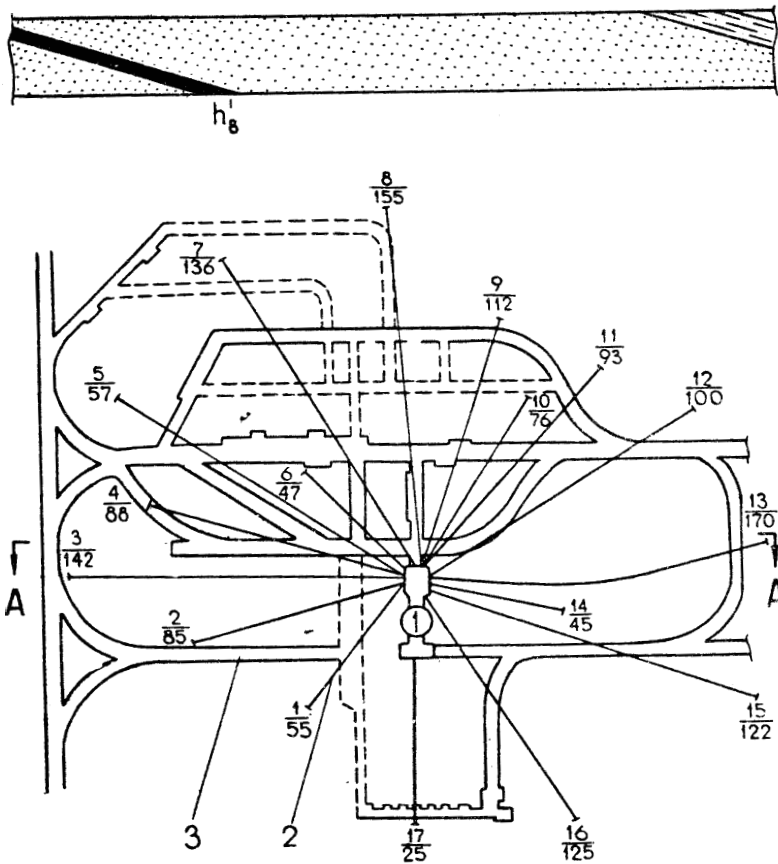

Figure 1. Layout scheme of grout holes in 960-m-level shaft station

1 - Main shaft with shaft bays, 2 - Boreholes, 3 - Excavations driven in grouted strata.

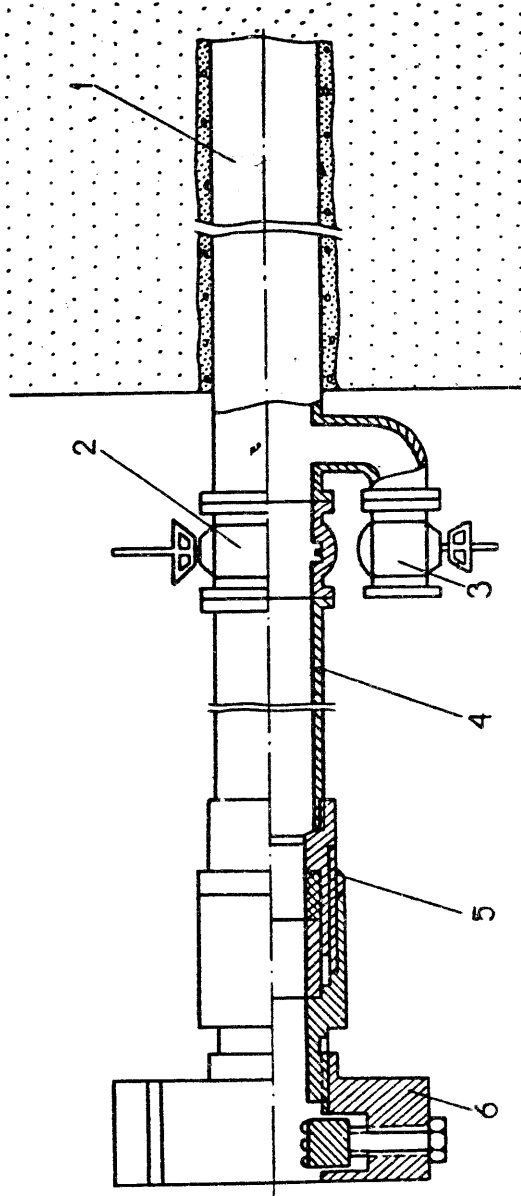

Figure 2. Borehole collar equipment  
1 - Standpipe, 2 - Sluce valve, 3 - Sluce valve for  
flushing fluid discharge, 4 - Gate chamber pipe,  
5 - Sealing device, 6 - Chuck

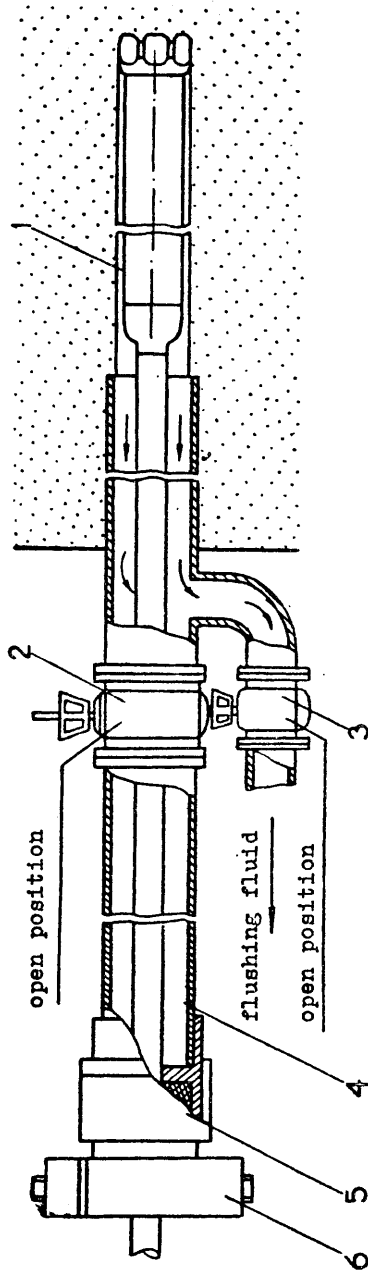

Figure 3 - Drilling scheme in the presence of pressurized water  
1 - Core drilling string, 2 - Sluce valve,  
3 - Sluce valve for flushing fluid discharge,  
4 - Gate chamber pipe, 5 - Sealing device, 6 - Chuck

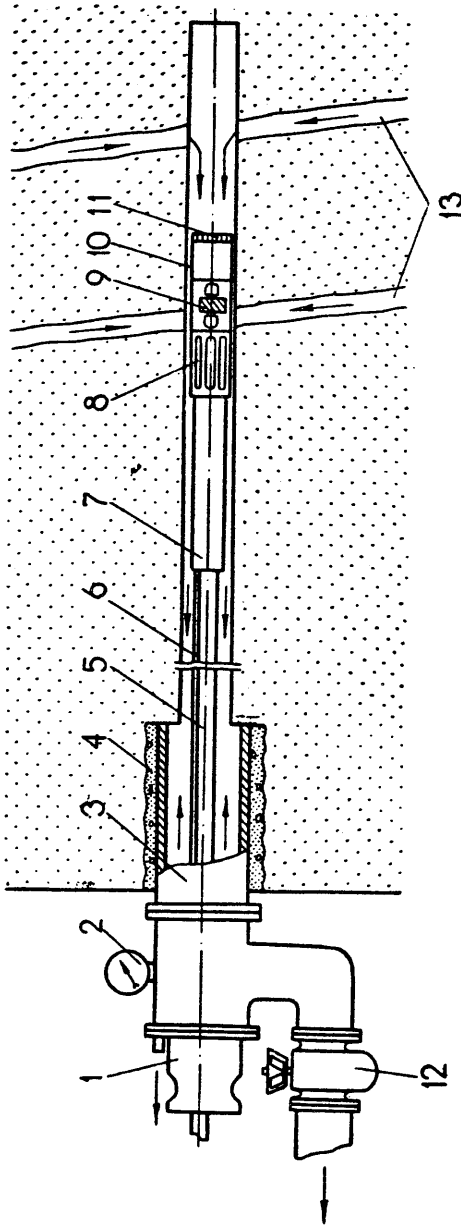

Figure 4 - Scheme of flowmetering investigations in horizontal holes  
 1 - Preventer, 2 - Pressure gauge, 3 - Casing, 4 - Cement,  
 5 - Drill pipes, 6 - Cable, 7 - Sleeve, 8 - Grating,  
 9 - Spinner, 10 - Sensing unit, 11 - Slots,  
 12 - Sluice valve for flushing fluid discharge, 13 - Fairing,  
 14 - Water bearing fissured zones

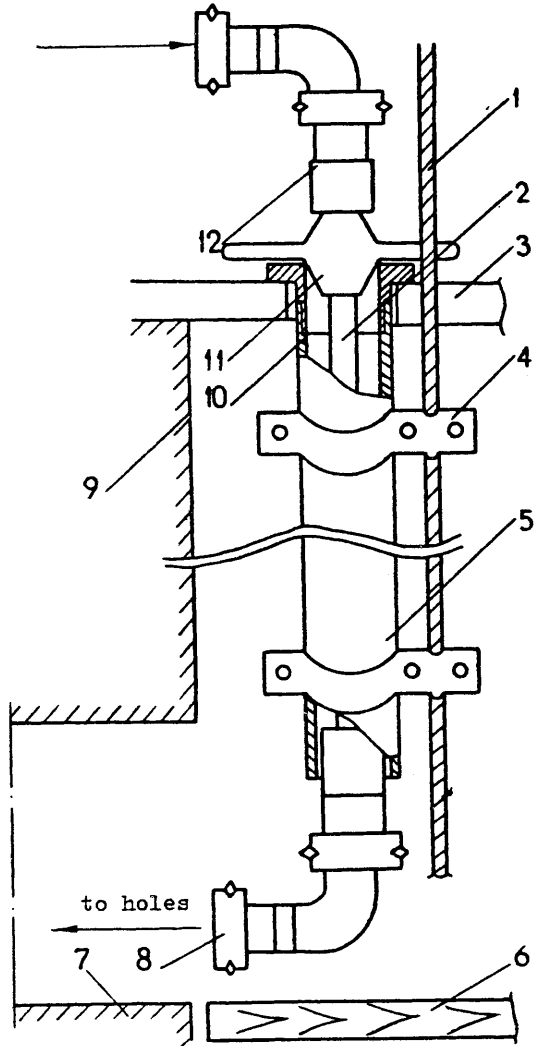

Figure 5 - High-pressure pipeline design for a mine shaft

- 1 - Cable, 2 - High-pressure pipes,
- 3 - Shaft collar stage at zero level, 4 - Grips,
- 5 - Protective piping, 6 - Scaffold, 7 - Shaft bay,
- 8 - Hinge adapters, 9 - Shaft wall, 10 - Saddle support for protective piping, 11 - Carrying grips for high-pressure pipes, 12 - Reducer.



clay-cement grout, prepared at the surface plant, was injected according to the squeeze pattern. Preparation and injection of the clay-cement grout was carried out by means of high-production mixing units 2SMN-20 and cementation units CA-320M. The initial clay slurry was prepared at the mud plant located in the central mine site.

Maximum injection pressure amounted to  $160\text{--}220 \text{ kgf/cm}^2$  with an instantaneous injection outgo of 6-8 l/s.

The quality of the sealing barrier formed was controlled by water pressurizing the treated zone under a given pressure that was calculated taking into account future geometrical dimensions of the excavation, fissure opening, structural-mechanical properties of the clay-cement grout and hydrostatic pressure head within the treated zone. On completion of the pressurizing, the hole was redrilled and deepened to the next fissured zone.

To more easily accommodate operations in the mine shaft, a new design of the high-pressure injection pipeline was proposed (Fig.5). The pipeline consists of two casings. The first one with a diameter of 50 mm is an injection pipeline, the second one with a diameter of 108 mm is a protective casing. The pipeline is suspended on a cable fastened by means of grips. To prevent the pipeline's wear during injection as a result of vibration, it is equipped with protectors in every 50 m.

All the operations on the advanced grouting of water bearing sandstone were finalized prior to the commencement of the 960-m-level shaft station drivage and coordinated with sinking of the main shaft to its project depth.

#### RESULTS

During drivage in the zone of grouting, more than 300 grouted fissures were encountered with widths from 0.001 m to 0.4 m. The measured total residual inflow into the 960-m-level shaft station on completion of the advanced grouting programme was about  $3 \text{ m}^3/\text{hr}$  versus the anticipated inflow of  $1430 \text{ m}^3/\text{hr}$ .

#### SUMMARY

The new method of the advanced grouting of water bearing rock while driving mine shaft stations or a series of horizontal workings has considerable advantages over the conventional from-the-face cementation method ensuring :

- o guaranteed water shut-off with a substantial reduction of labour consumption and an increase in safety;
- o simultaneous grouting operations and shaft sinking;
- o the most labour consuming operations of preparation and injection of grout take place on the surface;
- o an increase in advance rates due to elimination of stoppages for drilling and grouting from the faces of drivages.

Application of the new pregrouting method while driving the 960-m-level shaft station made it possible :

- o to reduce construction time of the shaft station by 24 months;
- o to commission the Nagolchanskaya 1-2 Mine 12 months earlier than the planned time;
- o to bring down construction cost of the shaft station by 19.5%;
- o to gain considerable cost saving in the replayment of capital investments due to reducing construction time and commissioning the Nagolchanskaya 1-2 Mine ahead of schedule.

#### REFERENCES

1. Velikiy, I. G., Tsapenko, A. A., Kipko, E. Ja., Polozov, Ju. A., 'Primenenie glinotsementnogo rastvora dlia likvidatsii catastrophic-heskih proryvov vody pri prohodke shahtnyh stvolov', (Application of clay-cement grout for elimination of catastrophic inundations during shaft sinking), Shahtnoe Stroitelstvo (Mine Construction Journal) (in Russian), Vol.2, p.4, (1974).
2. Kipko, E. J., Polozov, Ju. A., Lagunov, V. A., Spichak, Ju. N., 'Novy metod predvaritelnogo tamponazha obvodnennyh porod okolostvolnyh dvorov shaht', (New method of pregrouting water bearing rocks in mine shaft stations), Shahtnoe Stroitelstvo (Mine Construction Journal) (in Russian), Vol.4, p.20 (1978).